

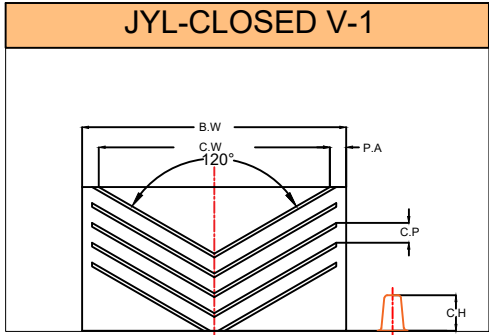

Chevron Conveyor Belt

PCB
Pro Conveyor Belt



B.W	C.W	C.P	C.H
1400	700	30	2.5

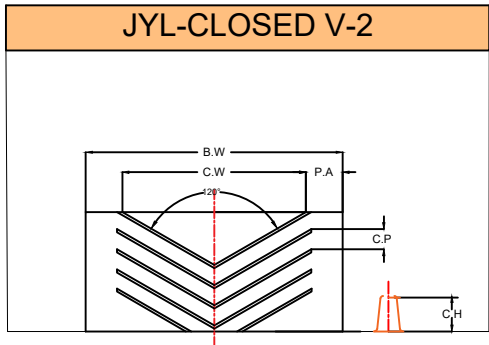

B.W	C.W	C.P	C.H
1400	1000	55	5

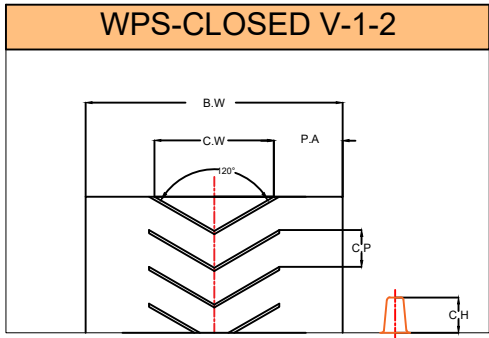

B.W	C.W	C.P	C.H
1200	650	200	11
			6.5

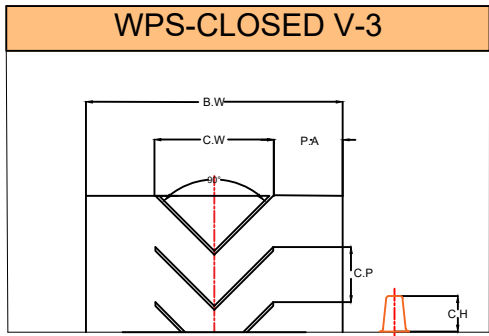

B.W	C.W	C.P	C.H
800	600	300	6

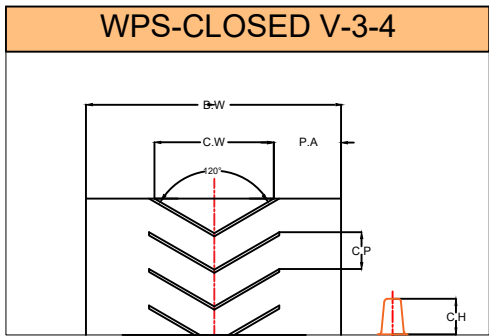

B.W	C.W	C.P	C.H
1400	800	200	6.5
			11

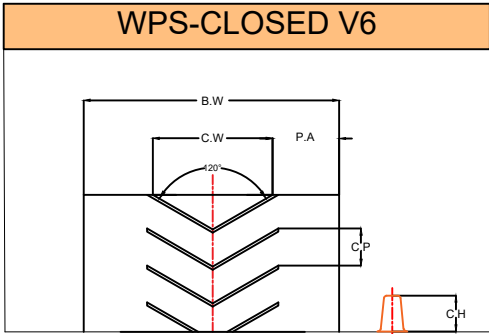

B.W	C.W	C.P	C.H
1400	800	300	15

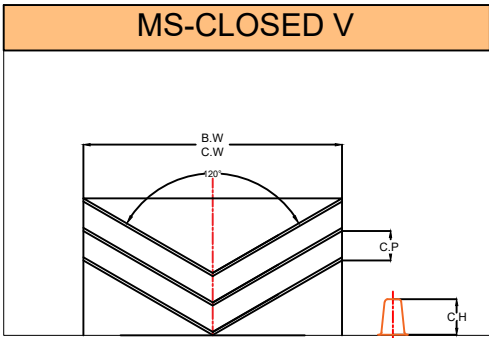

B.W	C.W	C.P	C.H
1400	1400	80	6

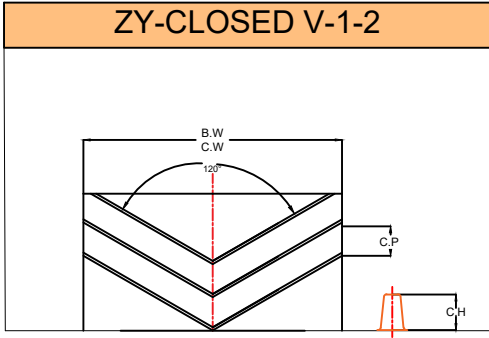

B.W	C.W	C.P	C.H
1400	1400	100	11
			6.5

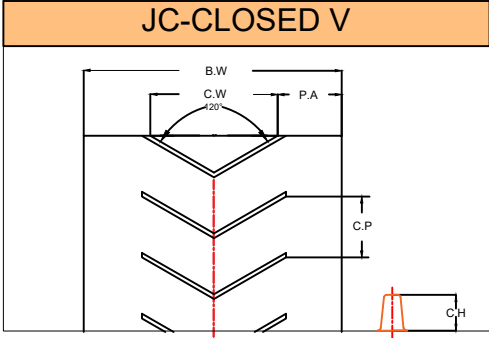

B.W	C.W	C.P	C.H
900	460	220	20

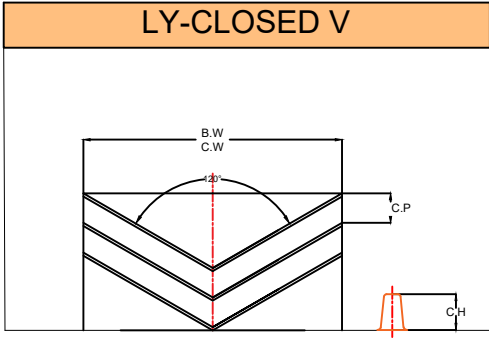

B.W	C.W	C.P	C.H
1000	1200	80	5

JYL-OPEN V-1

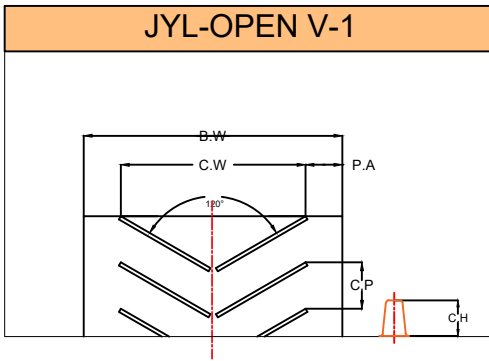

B.W	C.W	C.P	C.H
1400	1000	250	10

JYL-OPEN V-2

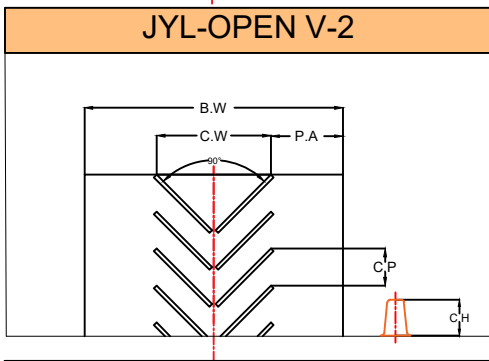

B.W	C.W	C.P	C.H
1400	620	200	15

WPS-OPEN V

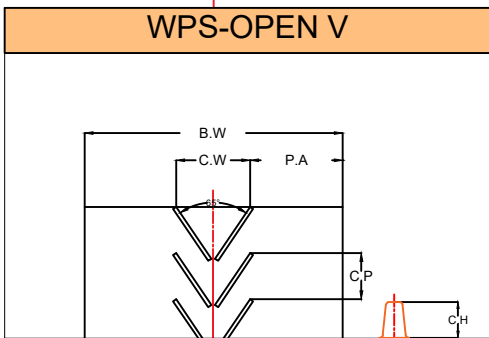

B.W	C.W	C.P	C.H
1200	400	250	15

LY-OPEN V

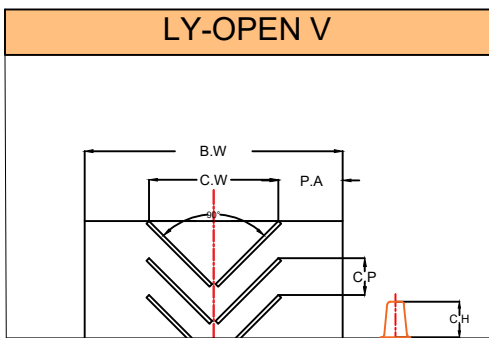

B.W	C.W	C.P	C.H
800	400-600	250	15

SW-OPEN V

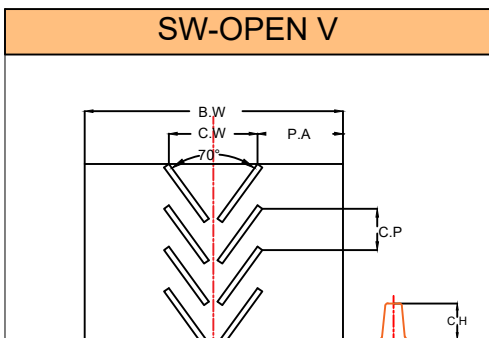

B.W	C.W	C.P	C.H
400-550	300	146	15
600-650	450	219	
700-1000	600	328	
400-850	380	250	
600-650	450	225	

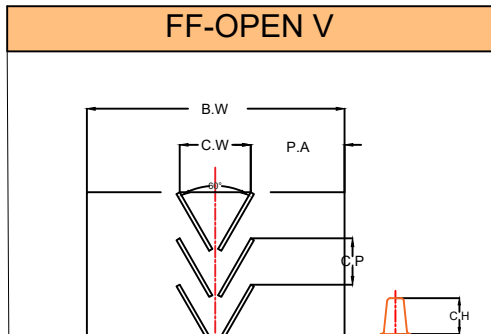

B.W	C.W	C.P	C.H
500	385	250	15
600			
650			
800			
1000	750	300	
1200			
1000	450	300	

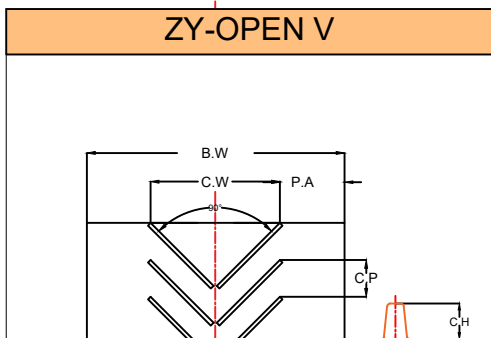

B.W	C.W	C.P	C.H
400-1050	385	250	15
700-1050	600		
800-1250	750		

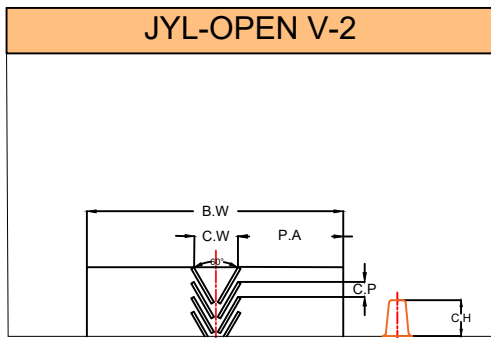

B.W	C.W	C.P	C.H
460	240	80	5

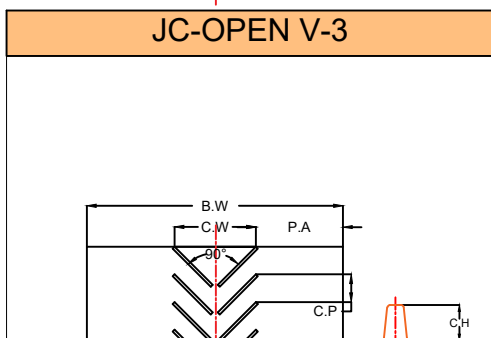

B.W	C.W	C.P	C.H
500	440	150	10

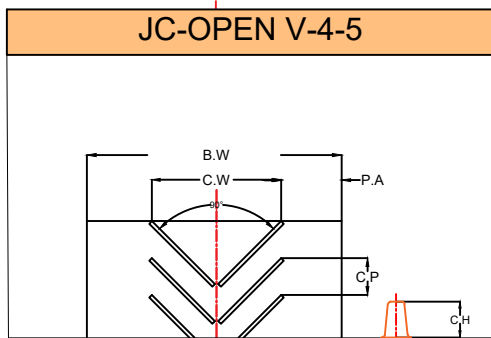

B.W	C.W	C.P	C.H
650	504	60	5
		130	18

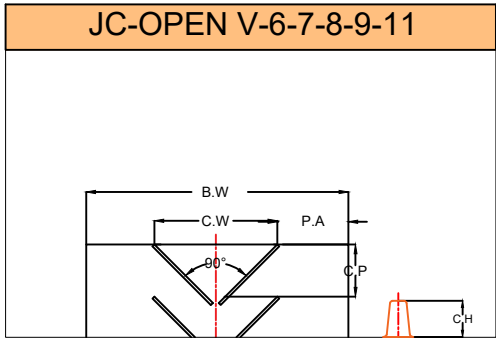

B.W	C.W	C.P	C.H
800	660	280	5
		130	8
		300	16
900	760	260	8
	770	265	

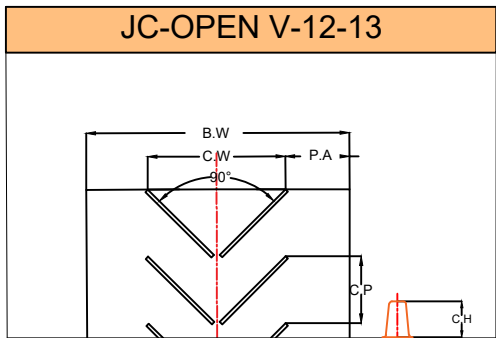

B.W	C.W	C.P	C.H
1000	740	357	10
		360	14

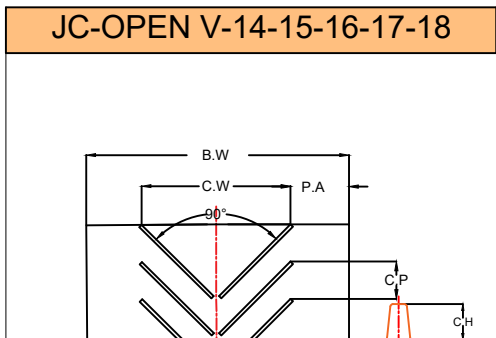

B.W	C.W	C.P	C.H
1200	1000	330	10
1050	640	150	
1400	1200	200	
1070	900		
1300	790		

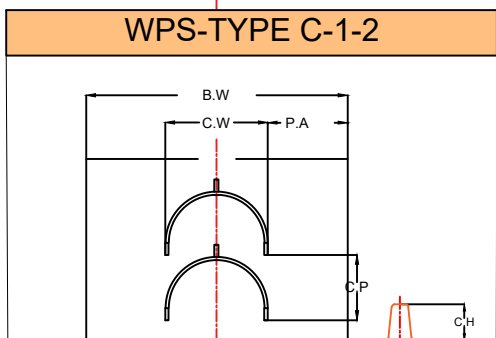

B.W	C.W	C.P	C.H
1200	550	350	15
			32

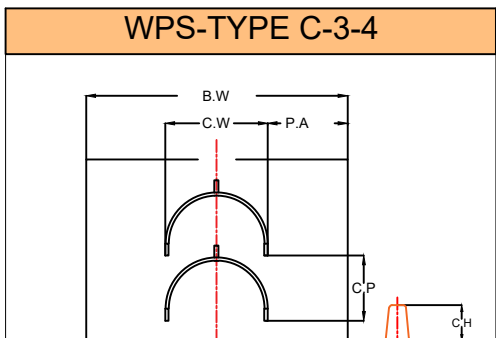

B.W	C.W	C.P	C.H
1400	700	400	15
			30

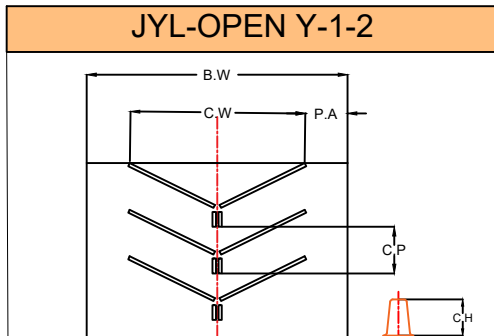

B.W	C.W	C.P	C.H
1200	550	350	15
			32

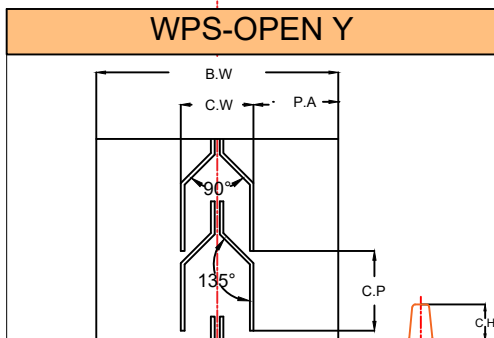

B.W	C.W	C.P	C.H
1000	300	330	17

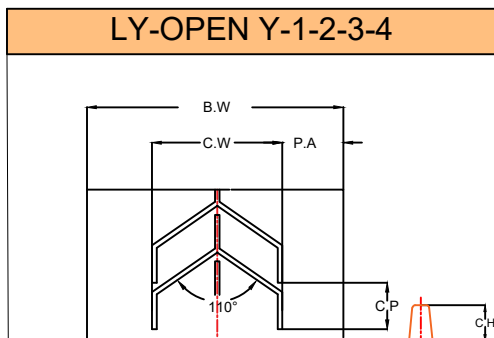

B.W	C.W	C.P	C.H
1200	300	330	17
	630		
	440	250	25
	500		

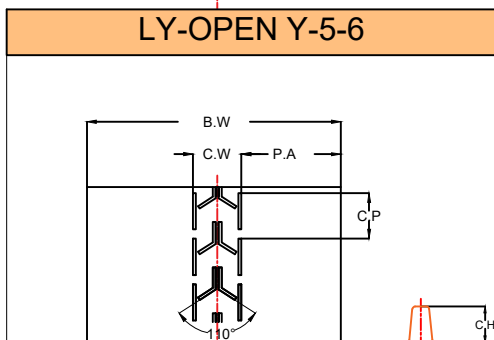

B.W	C.W	C.P	C.H
1200	260	245	25
	440		

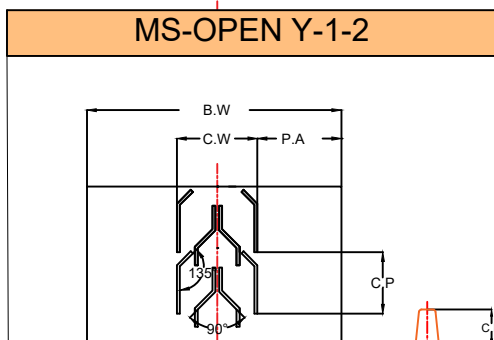

B.W	C.W	C.P	C.H
1300	435	330	17
	624		

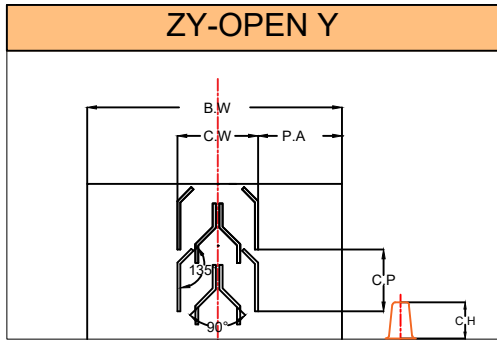

B.W	C.W	C.P	C.H
400-1050	300	330	17
550-1050	440		
650-1050	550		
750-1050	630		
1100-1250	750		
1100-1450	950		

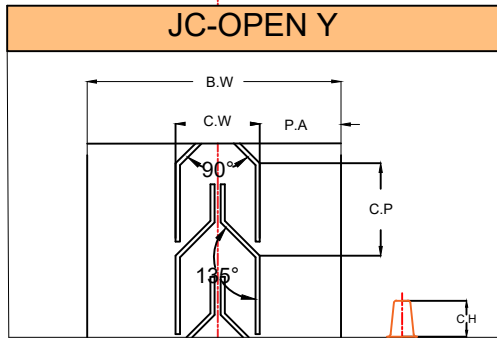

B.W	C.W	C.P	C.H
500	313	300	17

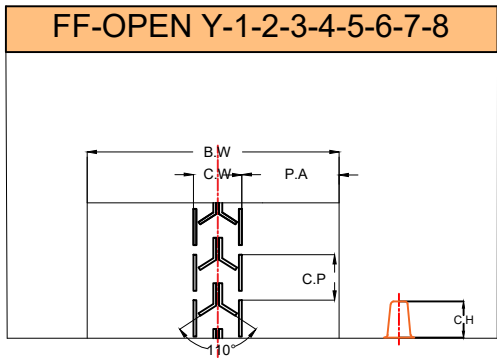

B.W	C.W	C.P	C.H
400	230	250	25
500	330		
650	440		16
800	540		25
			16
			25
1000	750		25
500	330		16

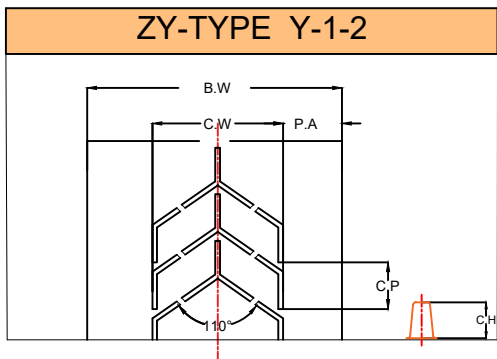

B.W	C.W	C.P	C.H
700-1050	600	330	32
900-1250	800		

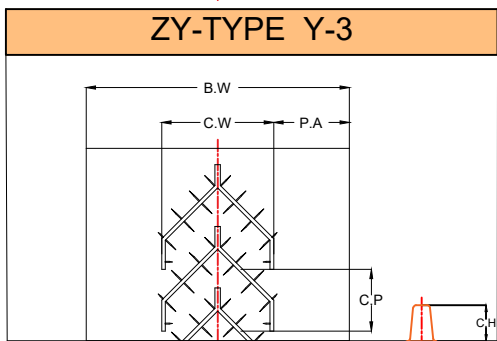

B.W	C.W	C.P	C.H
1410	565	330	40

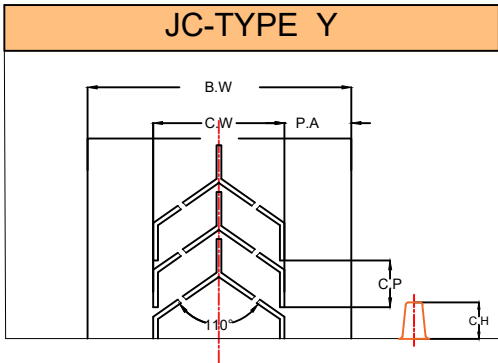

B.W	C.W	C.P	C.H
800	585	330	28

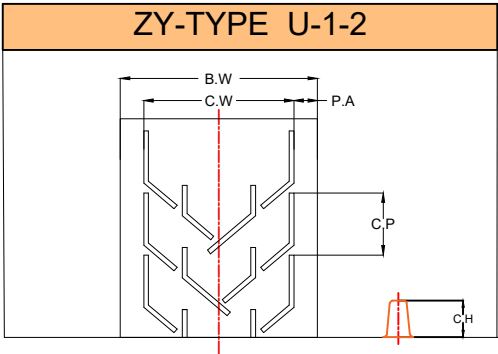

B.W	C.W	C.P	C.H
1400	750	330	32
600-1050	460		
700-1050	580		
800-1050	630		
900-1050	750		

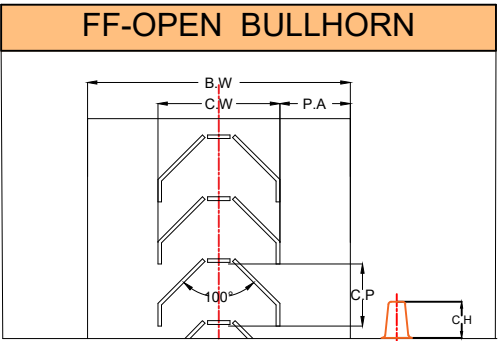

B.W	C.W	C.P	C.H
500	330	330	25
650	440		
400	230		
650	550		
800			
1000	750		
1200			

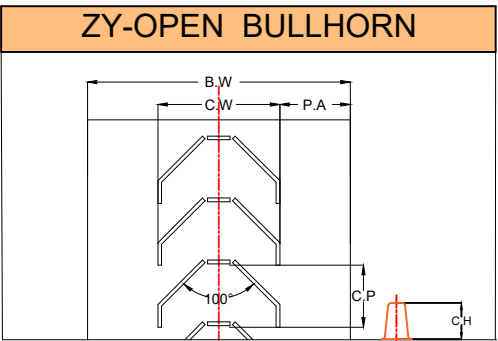

B.W	C.W	C.P	C.H
600-1050	450	330	25
650-1050	550		
1000-1250	750		

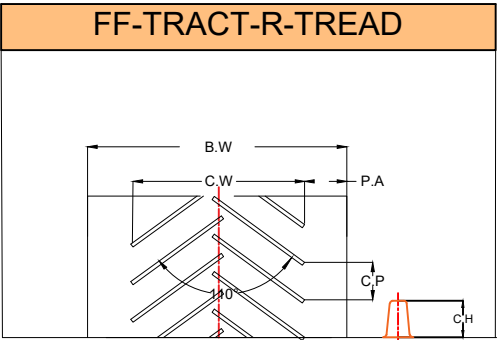

B.W	C.W	C.P	C.H
1200	914	200	25

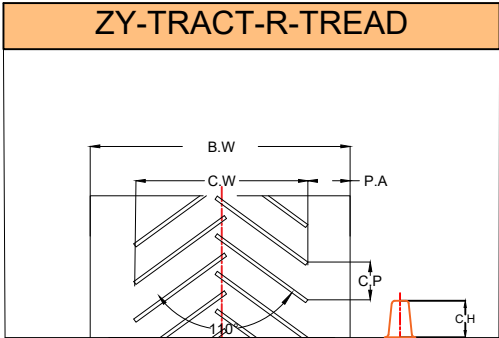

B.W	C.W	C.P	C.H
1500	900	250	20
1200		300	

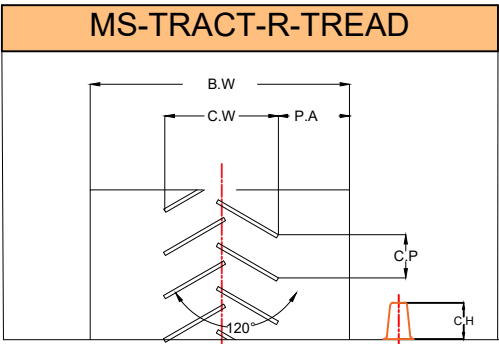

B.W	C.W	C.P	C.H
1200	600	230	15

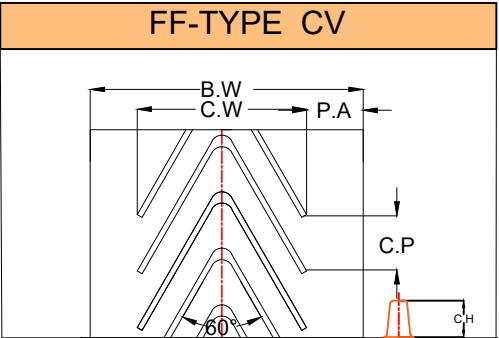

B.W	C.W	C.P	C.H
1400	1000	70	10
	800		6
1000	650		
	600		
	800		

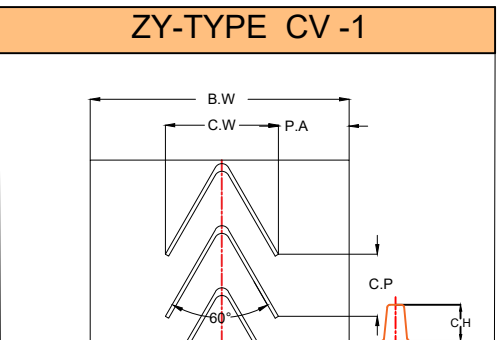

B.W	C.W	C.P	C.H
400-1050	330	250	15
600-1050	450	300	

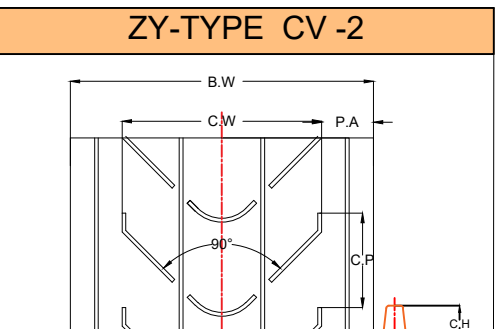

B.W	C.W	C.P	C.H
1610	1060	500	25

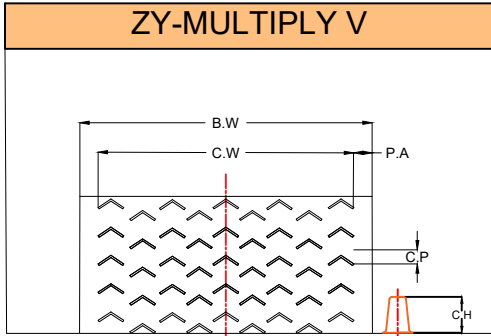

B.W	C.W	C.P	C.H
1610	1533	76	6

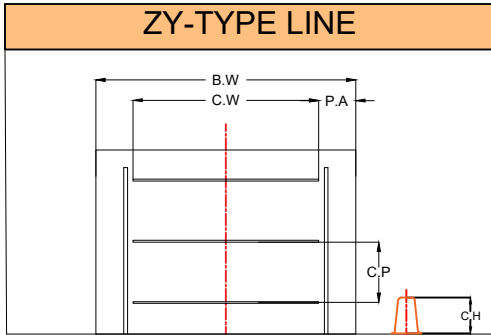

B.W	C.W	C.P	C.H
1410	1000	333	13

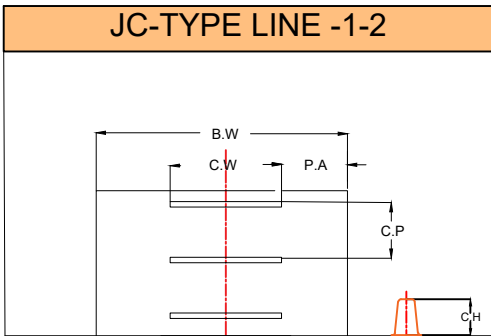

B.W	C.W	C.P	C.H
350	300	150	6
	330		
500	500	330	20

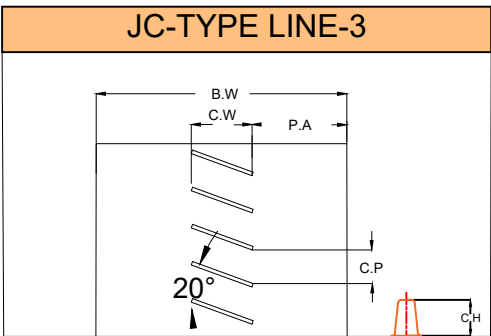

B.W	C.W	C.P	C.H
400	180	100	5

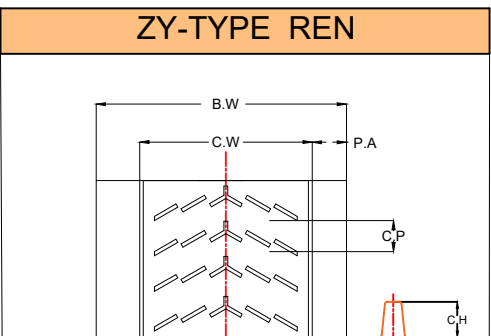

B.W	C.W	C.P	C.H
1610	890	190	30



PCB(Pro Conveyor Belt) conveyor belts for all kind of applications – up to the strongest and heaviest belts ever built. Please contact us for any assistance regarding your conveyor belt requirements.

PCB (Pro Conveyor Belt) has the most modern testing centre worldwide for developing conveyor belts. Extensive quality tests ensure the technological lead of PCB conveyor belts.

PCB production locations meet the ISO 9001 quality standard. The certification according to ISO 9001 comprises quality assurance during development, production, assembly and distribution. It therefore completely covers all of the areas which lead to higher standards of products and services. PCB fabricates according to all the nationally relevant quality standards like DIN, SANS, MSHA, RMA, BS, AS, CSA, etc.

Pro Conveyor Belt Co., Ltd

Office Address: Shenzhen Road, Qingdao City, Shandong Province, China

Factory Address: HUtouai Town, Laizhou city, Shandong Province, China

Phone: 0086-532-80999210

E-mail: pcb@pro-cb.com

Web: <http://www.pro-cb.com>

The content of this brochure has been compiled to the best of our knowledge. All details are not binding, even with regard to possible third party industrial rights. We reserve ourselves the right to make technical modifications due to further developments, at any time. No liability is accepted for the recommendations and details given in this brochure. © Pro Conveyor Belt Co., Ltd All rights reserved.

PCB
Pro Conveyor Belt